



AQUARIOUS PUMP COMPANY

Model 12NHTL-F Redi-Prime®

PUMP SPECIFICATIONS

- **Size:** 12NNF - 12" discharge x 12" suction with 125# cast iron flanges.
- **Casing:** Cast Iron.
- **Impeller:** Enclosed - 2 vane. Handles 4.25" diameter solids.
- **Wear Rings:** Replaceable. (Double wear rings available).
- **Seal:** Aquarius patented Cycloseal® design with Run-Dry oil lubrication system. John Crane T-2 single mechanical seal with Viton® elastomers, stainless steel hardware and tungsten- vs. silicon-carbide seal faces for abrasion resistance.
- **Check Valve:** SwingFlex® Val-Matic®.
- **Shaft Sleeve:** Heat treated 416 stainless steel.
- **Bearings:** Heavy duty, grease lubricated, deep groove ball bearings, with a minimum of 50,000 hours bearing life.
- **Hardware:** Stainless steel float linkage. A positive seating vacuum priming valve prevents water carry-over to the vacuum, pump or atmosphere.
- **Vacuum Pump** - 50 SCFM Maximum.

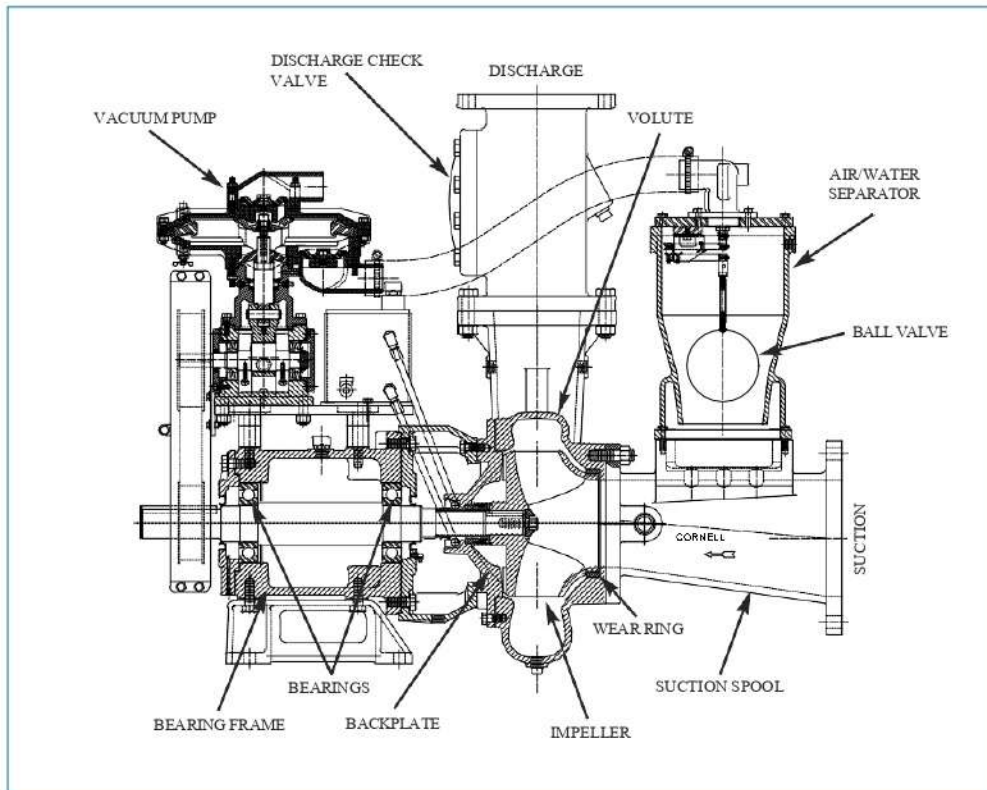

PUMP DIMENSIONS

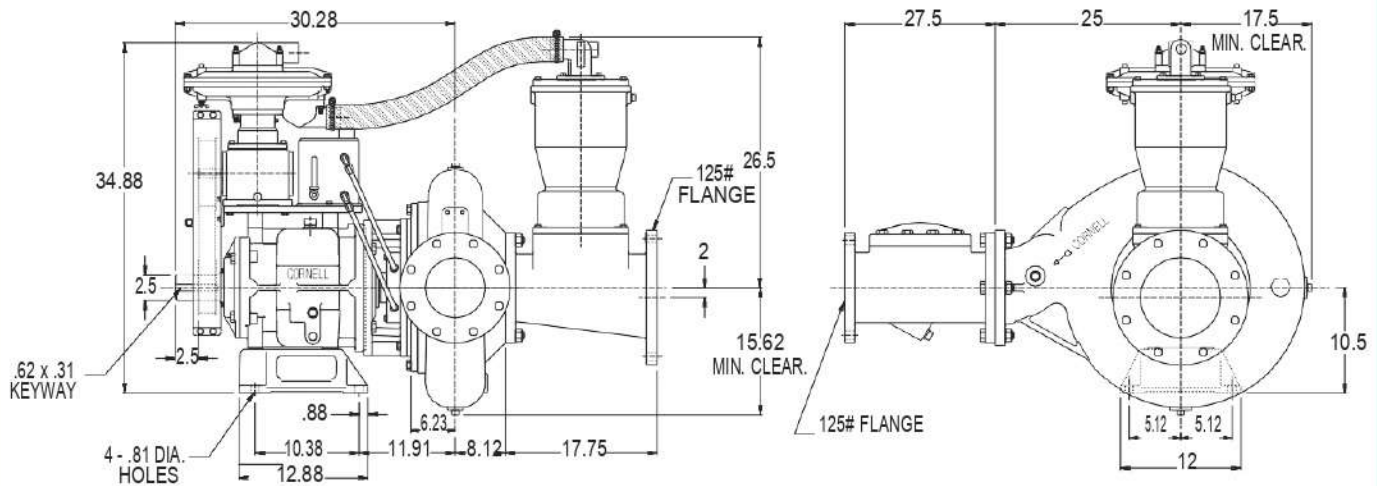

- NOTES:**
1. Frame mounting foot thickness is .75".
 2. Flange connection dimension can vary ± 12 inch.
 3. Do not use for construction unless certified.

PERFORMANCE CURVES

Feet x .305 = Meters
 Inches x 25.4 = Millimeters
 GPM x .227 = Cubic Meters/Hour
 GPM x 3.785 = Liters/Minute
 HP x .746 = KW

Speed	Impeller Dia.	Style	Solids Dia.	N _S	Suction	Discharge	No. vanes
VARIOUS	14"	ENCLOSED	4.25"	3900	12"	12"	2

SINGLE VOLUTE MOUNTING CONFIG.: F, EM

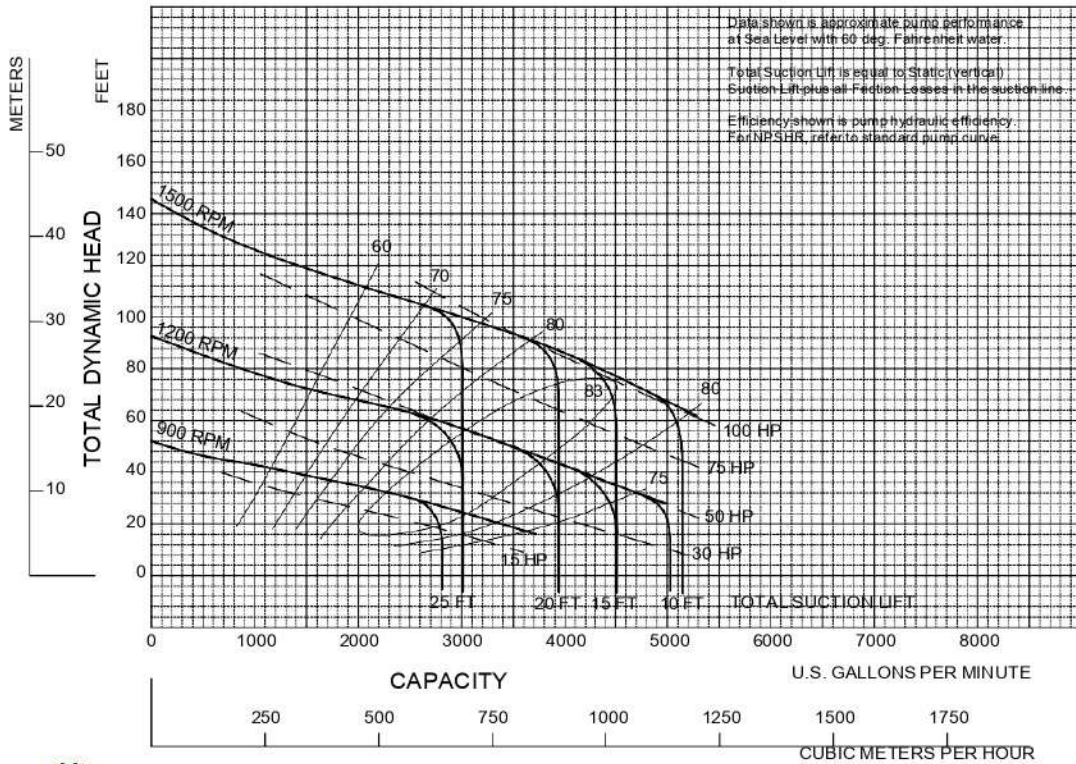

Data shown is approximate pump performance at Sea Level with 60 deg. Fahrenheit water.
 Total Suction Lift is equal to Static (vertical) Suction Lift plus all Friction Losses in the suction line.
 Efficiency shown is pump hydraulic efficiency. For NPSHR, refer to standard pump curves.

Performances shown are for cool water, frame mounted configuration with Cyobseal®. Other liquids or mounting configurations may require performance adjustments.
 Add 1.5 HP for belt driven diaphragm vacuum pump. Performance curve does not include discharge check valve losses.



Aquarius Pump Company

8/30/01

Aquarius Pump Company

ISO9001: 2000 CERTIFIED