

**AQUARIUS PUMP COMPANY****3HA****STANDARD SPECIFICATION****DISCHARGE**

- 3 inch flanged discharge

SUCTION

- 6 inch flanged suction

BALANCE LINE**IMPELLER**

- Enclosed silicon bronze

VOLUTE

- Right hand tangential discharge, four positions
- Mechanical Seal or Traditional Packing - Single type 1 carbon ceramic mechanical seal: Cycloseal® design, Run-Dry® available

MATERIALS OF CONSTRUCTION

- Cast iron bronze fitted
- Other materials available

MOUNTING CONFIGURATIONS**CLOSE COUPLED ELECTRIC**

- Aquarius's Energy Efficient Design

FRAME MOUNT

- Aquarius F16
- Aquarius F18

ENGINE BRACKET

- Aquarius EM16 (SAE 1, 2, 3, 4)
- Aquarius EM18 (SAE 1, 2, 3, 4)

REDI-PRIME® SELF PRIMING SYSTEM

- Available

PRODUCT AVAILABILITY**QUICK SHIP**

- Finished Product Regularly Stocked
- Specific Configuration, Specific Trim (48 Hours)

PREFERRED PUMP

- Finished Components Regularly Stocked
- Various Configurations, Variable Trim (10 business days)

SPECIALTY PUMP

- Aquarius Pump Company will design and manufacture a variation of this pump specifically designed for your application

FEATURES AND BENEFITS**EXPERIENCE**

- Over 50 years in the centrifugal pump business

OPTIMUM HYDRAULICS

- In house engineering staff and test lab facilities

STRONG LOCAL DEALER SUPPORT

- Our agricultural products are sold only through authorized dealerships
- Dealerships provide full service to customers from sales to replacement parts
- Dealers maintain and improve their knowledge at educational activities like Aquarius's "Pump School"

EXCEPTIONAL DESIGN**EFFICIENCY**

- Effectively converts energy into fluid flow and pressure

LONG PRODUCT LIFE

- Thick walled castings
- Heavy duty shafts
- 20,000 hour bearings
- Replaceable wear rings and shaft sleeves
- Reduced thrust load through design and balance lines where appropriate

3HA

NEW PAGE

3HA

Feet x .305 = Meters
 Inches x 25.4 = Millimeters
 GPM x .227 = Cubic Meters/Hour
 GPM x 3.785 = Liters/Minute
 HP x .746 = KW

Speed	Impeller Dia.	Style	Solids Dia.	N _S	Suction	Discharge	No. vanes
VARIOUS	VARIOUS	ENCLOSED	.50"	800	6"	3"	6

SINGLE VOLUTE MOUNTING CONFIG.: CC, VM, F, VF, EM, VC

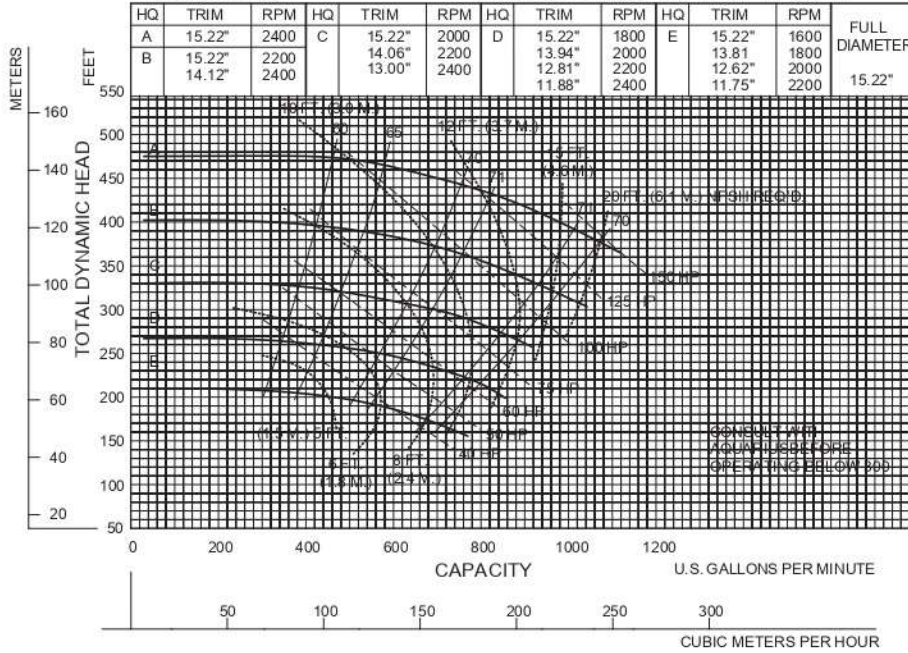

Performance shown above is for stock motor. Please consult factory for alternate motor configurations. Other mounting styles or options may require horsepower or motor performance adjustments.

9/15/99



Aquarius Pump Company

3HA - VARIOUS RPM

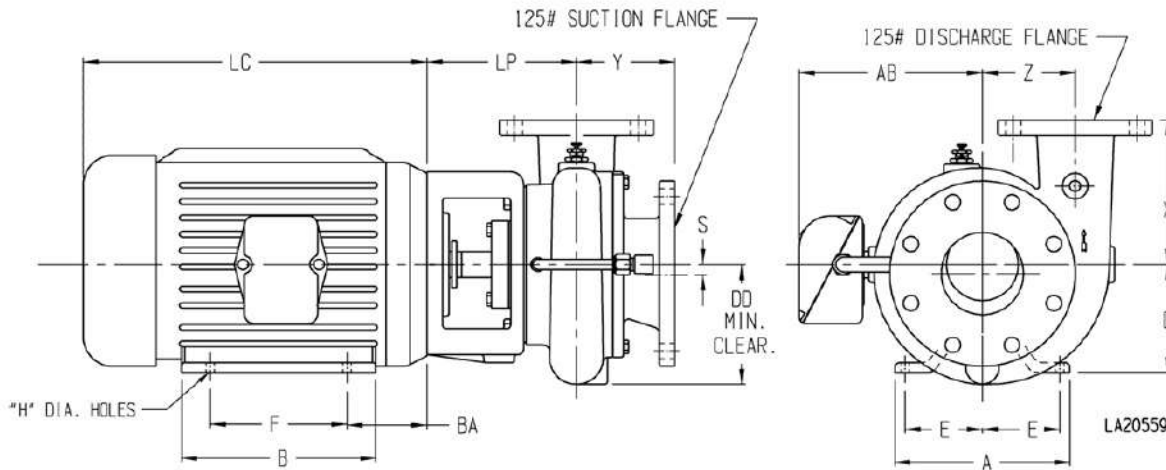

PUMP DIMENSIONS

MODEL	CONNECTION		DISCH. INCR.	AK DIM.	DD	S	X	Y	Z	LP
	DISCH.	SUCT.								
2.5H	2.5	4	90°	8.5	9.62	0.44	11	8.28	7.75	7.66
				12.5	9.62	0.44	11	8.28	7.75	7.66
3HA	3	6	90°	12.5	11.12	0.44	10	8.53	8.5	10.09
3HC	3	6	90°	12.5	11.12	0.44	10	8.53	8.5	10.09
4HC	4	8	90°	12.5	12.62	0.88	11	10.88	9.75	11.19
4HH	4	6	90°	12.5	15	0.44	9.5	8.97	11.25	10.12
				16.5	16.25	0.44	11	10.56	10.25	10.81
5H	5	8	90°	12.5	14.75	0.88	13	9.66	11.62	10.15
				16.5	16.25	0.44	11	10.56	10.25	10.81
6H	6	8	90°	12.5	14.75	0.44	14	10.18	11.62	10.12
				16.5	14.75	0.44	14	10.18	11.62	10.12
6HH	6	8	90°	12.5	17.12	0.44	12	10.43	12	11.13
				16.5	17.12	0.44	12	10.43	12	11.13
8H	8	10	90°	12.5	16.75	0.75	13	10.41	11.5	11.38
				16.5	16.75	0.75	13	10.41	11.5	11.38

MOTOR DIMENSION

MOTOR FRAME	AK DIM.	A	B	D	E	F	H	AB	BA	LC
213-5	8.5	9.5	8	5.25	4.25	7	0.41	7.94	4.5	13.69
254-6	8.5	11.25	11.25	6.25	5	10	0.53	9.5	5	17.94
284-6	12.5	12.25	12.25	7	5.5	11	0.53	11.37	5	21.31
324-6	12.5	14.25	13.75	8	6.25	12	0.66	12.22	5.5	22.19
364-5	12.5	15.75	14	9	7	12.25	0.66	13.2	6.12	24.31
404-5	12.5	18.5	16.62	10	8	13.75	0.81	16.39	6.88	29.97
444-5	16.5	21.5	19.5	11	9	16.5	0.81	19.06	7.5	31