



# AQUARIUS PUMP COMPANY

## 3STH

### AVAILABLE MOUNTING CONFIGURATIONS

3STH-F FRAME MOUNT  
3STH-EM ENGINE MOUNT

### OPERATING LEVELS

MIN FLOW	300 GPM	68.1 m <sup>3</sup> /h
MAX FLOW	1050 GPM	238.5 m <sup>3</sup> /h
DISCHARGE SIZE	3"	75 mm
SUCTION SIZE	4"	100 mm
SOLIDS HANDLING	2.50"	63.5 mm
MAX SPEED	2200 RPM	2200 RPM
SHUT-OFF HEAD	277'	84.4 m
BEP HEAD	205'	62.5 m
BEP FLOW	860 GPM	195.3 m <sup>3</sup> /h
BEP EFFICIENCY	59%	59%



A typical picture of the pump is shown. Please contact Aquarius Pump Company for further details. All information is approximate and for general guidance only.

### HIGH-HEAD SELF-PRIMER

Aquarius's self-priming pump, with industry-leading efficiency, runs several percentage points higher than other manufacturers. Features patented Cycloseal<sup>®</sup> system and uniquely designed volute for best performance, with a 4" suction and 3" discharge.

PARTS	STANDARD MATERIAL (ALL IRON)
VOLUTE CASING	DUCTILE IRON, ASTM A536, 65-45-12
IMPELLER	DUCTILE IRON, ASTM A536, 100-70-03
IMPELLER SCREW	304 STAINLESS STEEL
BACKPLATE/BACKET	DUCTILE IRON, ASTM A536, 65-45-12
WEAR PLATE	MILD STEEL
BEARING FRAME	DUCTILE IRON, ASTM A536
SHAFT	17-4 PH STAINLESS STEEL
SHAFT SLEEVE	304 STAINLESS STEEL
FASTENERS	GRADE 5 STEEL
MECHANICAL SEAL	SILICON CARBIDE vs. SILICON CARBIDE, TYPE 2

- FIVE-YEAR warranty
- Optional self-cleaning wear plate
- Modular bearing frame
- Aquarius's Cycloseal<sup>®</sup> with type 2 seal
- Dual protection of bearings with external seal leakage monitor (vent to atmosphere)
- High Heads up to 277'

- High-efficiency design
- Oversized oil reservoir for better cooling
- Replaceable shaft sleeve
- Heavy-duty ductile iron construction
- Designed for SAE conversion
- High RPM Capability



AGRICULTURE



FOOD



INDUSTRIAL



MINING



MUNICIPAL



OIL & GAS



REFRIGERATION



RENTAL



**PRODUCT DATA SHEET**

# AQUARIUS PUMP COMPANY

## 3STH

### 3STH (VARIOUS RPM)

Performances shown are for S.G. 1.0 60°F water, close-coupled configuration. Other mounting styles or S.G. may require curve adjustments.	Speed	Impeller Dia.	Style	Volute	Solids Dia.	N <sub>s</sub>	Suction	Discharge	No. Vanes
	VARIOUS	12.38"	SEMI-OPEN	SINGLE	2.5"	1230	4"	3"	2

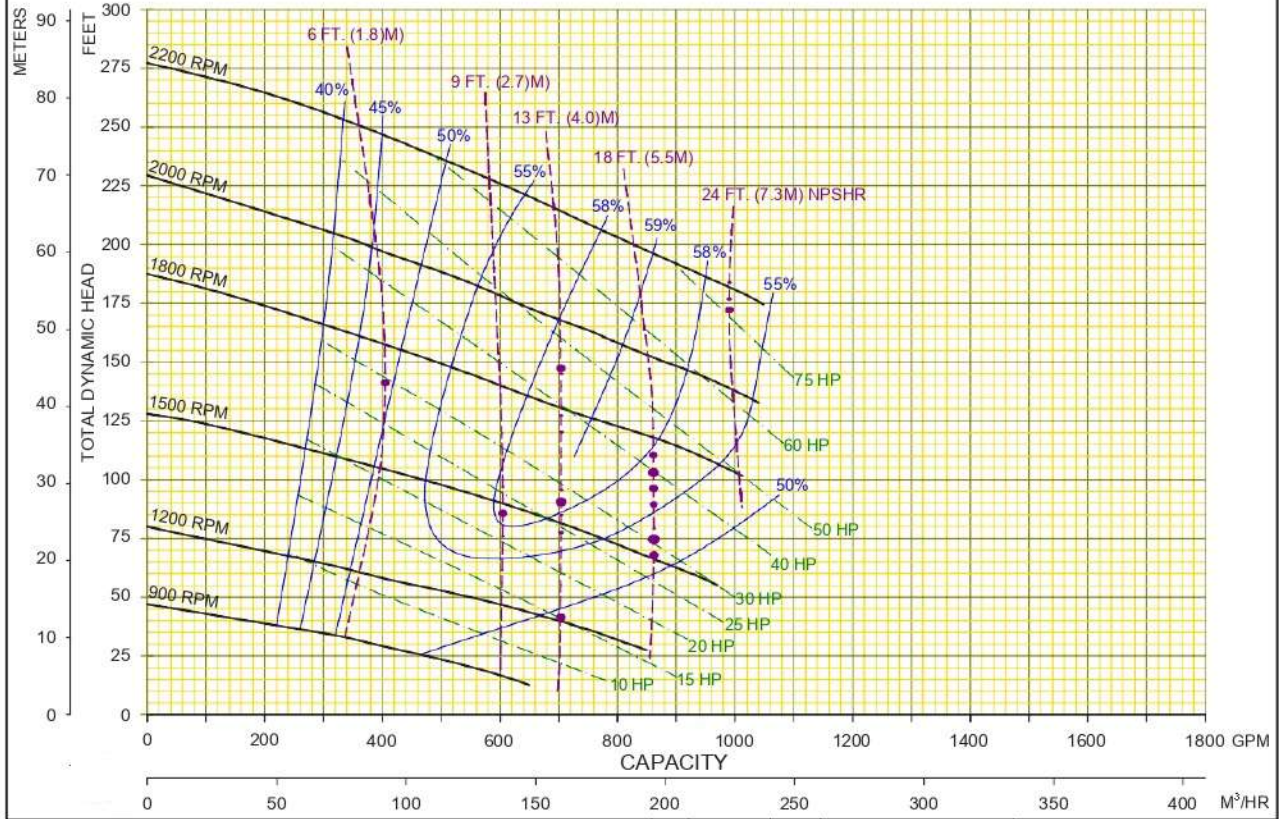

Aquarius Pump Company	00	07/31/14	CTG	MODEL: 3STH	CURVE NO. <b>3STHVA</b>
	00	07/31/14	CTG	TYPE: SELF-PRIMER	

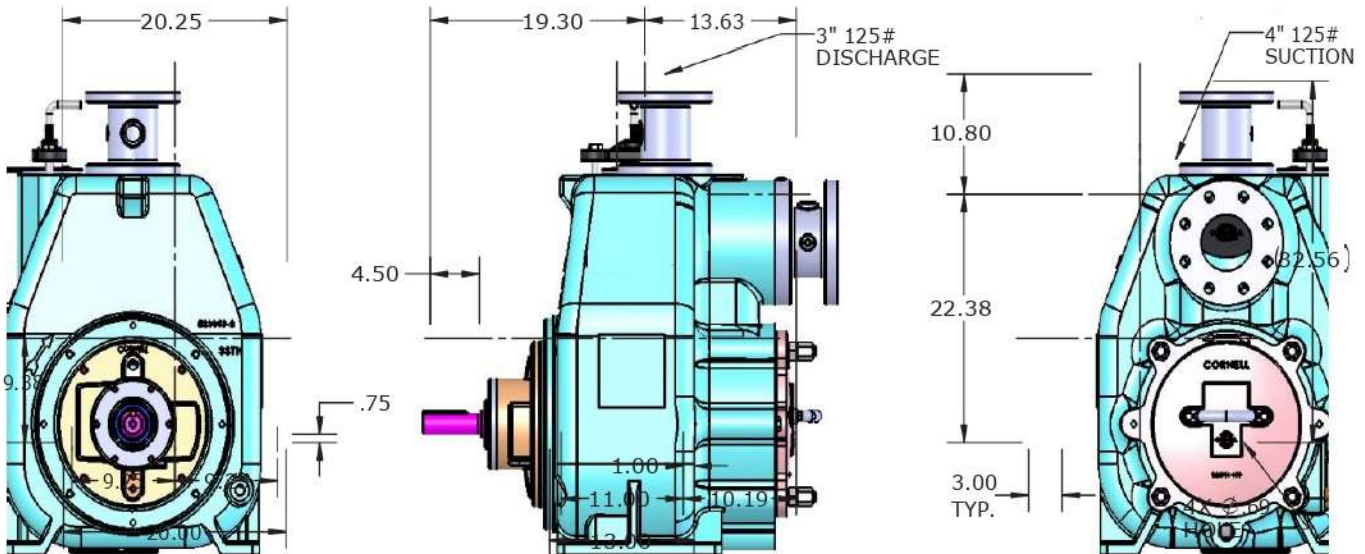

DS3STH-140826-P