



AQUARIUS PUMP COMPANY

4HH-CC

AVAILABLE MOUNTING CONFIGURATIONS

4HH-CC CLOSE COUPLED
4HH-VM VERTICAL CLOSE COUPLED

OPERATING LEVELS

MIN FLOW	250 GPM	56.8 m ³ /h
MAX FLOW	1380 GPM	313.4 m ³ /h
DISCHARGE SIZE	4"	102 mm
SUCTION SIZE	6"	152 mm
SOLIDS HANDLING	.62"	1.6 cm
MAX SPEED	1800 RPM	1800 RPM
SHUT-OFF HEAD	253'	77 m
BEP HEAD	210'	64 m
BEP FLOW	1170 GPM	265.7 m ³ /h
BEP PERCENT	81%	81%



A typical picture of the pump is shown. Please contact Aquarius Pump Company for further details. All information is approximate and for general guidance only.

PARTS	CAST IRON BRONZE FITTED (STANDARD)	ALL IRON
IMPELLER	BRONZE SAE 40 OR SILICON BRONZE	CAST IRON ASTM A48 CL30
VOLUTE	CAST IRON ASTM A48 CL30	CAST IRON ASTM A48 CL30
SHAFT	CARBON STEEL	CARBON STEEL
SHAFT SLEEVE	BRONZE SAE 660	416 STAINLESS STEEL
MOTOR	ODP W/ 1.15 SF	ODP W/ 1.15 SF
WEAR RINGS	BRONZE SAE 660	CAST IRON ASTM A48 CL30
SUCTION SPOOL	CAST IRON ASTM A48 CL30	CAST IRON ASTM A48 CL30
BACKPLATE	CAST IRON ASTM A48 CL30	CAST IRON ASTM A48 CL30
MECHANICAL SEAL (OPTIONAL)	T-1, BUNA, CARBON/CERAMIC/STAINLESS	T-1, BUNA, CARBON/CERAMIC/STAINLESS
PACKING	GRAPHITED ACRYLIC	GRAPHITED ACRYLIC

The 4HH pump is designed with Aquarius's renowned quality and durability. It features a 4" discharge, 6" suction, enclosed impeller, and flanged tangential double volute. Available in all-iron or bronze-fitted materials. Graphited acrylic packing is standard, with Aquarius's patented Cycloseal[®] available (with type 1 single mechanical seal). Optional motors include TEFC (other options available).

- Standard cast iron bronze fitted construction
- External hydraulic balance line
- Double volute construction
- Back pullout design
- Replaceable hub & suction wear rings
- Replaceable shaft sleeve
- "Shower curtain shield" bearing protection
- High efficiency hydraulics
- Low operating costs
- Two year warranty
- Other mechanical seal (Cycloseal[®]) and material options available



AGRICULTURE



FOOD



INDUSTRIAL



MINING



MUNICIPAL



OIL & GAS



REFRIGERATION



RENTAL



AQUARIUS PUMP COMPANY

4HH-CC

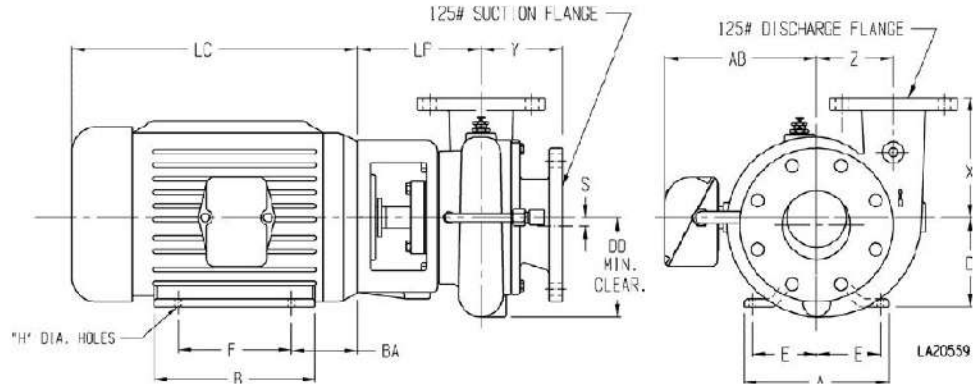

PUMP DIMENSIONS

MODEL	CONNECTION DISCH.	CONNECTION SUCT.	DISCH. INCR.	AK DIM.	DD	S	X	Y	Z	LP
2.5H	2.5	4	90°	8.5	9.62	0.44	11	8.28	7.75	7.66
				12.5	9.62	0.44	11	8.28	7.75	7.66
3HA	3	6	90°	12.5	11.12	0.44	10	8.53	8.5	10.09
3HC	3	6	90°	12.5	11.12	0.44	10	8.53	8.5	10.09
4HC	4	8	90°	12.5	12.62	0.88	11	10.88	9.75	11.19
4HH	4	6	90°	12.5	15	0.44	9.5	8.97	11.25	10.12
				16.5	16.25	0.44	11	10.56	10.25	10.81
5H	5	8	90°	12.5	14.75	0.88	13	9.66	11.62	10.15
				16.5	16.25	0.44	11	10.56	10.25	10.81
5HH	5	8	90°	12.5	16.25	0.44	11	10.56	10.25	10.81
				16.5	16.25	0.44	11	10.56	10.25	10.81
6H	6	8	90°	12.5	14.75	0.44	14	10.18	11.62	10.12
				16.5	14.75	0.44	14	10.18	11.62	10.12
6HH	6	8	90°	12.5	17.12	0.44	12	10.43	12	11.13
				16.5	17.12	0.44	12	10.43	12	11.13
8H	8	10	90°	12.5	16.75	0.75	13	10.41	11.5	11.38
				16.5	16.75	0.75	13	10.41	11.5	11.38

MOTOR DIMENSION

MOTOR FRAME	AK DIM.	A	B	D	E	F	H	AB	BA	LC
213-5	8.5	9.5	8	5.25	4.25	7	0.41	7.94	4.5	13.69
254-6	8.5	11.25	11.25	6.25	5	10	0.53	9.5	5	17.94
284-6	12.5	12.25	12.25	7	5.5	11	0.53	11.37	5	21.31
324-6	12.5	14.25	13.75	8	6.25	12	0.66	12.22	5.5	22.19
364-5	12.5	15.75	14	9	7	12.25	0.66	13.2	6.12	24.31
404-5	12.5	18.5	16.62	10	8	13.75	0.81	16.39	6.88	29.97
444-5	16.5	21.5	19.5	11	9	16.5	0.81	19.06	7.5	31

