



AQUARIUS PUMP COMPANY

6H-F

AVAILABLE MOUNTING CONFIGURATIONS

6H-RP-F REDI-PRIME FRAME MOUNT
 6H-F FRAME MOUNT
 6H-RP-EM REDI-PRIME ENGINE MOUNT
 6H-EM ENGINE MOUNT
 6H-VF VERTICAL FRAME MOUNT
 6H-VC VERTICAL COUPLED

OPERATING LEVELS

MIN FLOW	500 GPM	113.5 m ³ /h
MAX FLOW	3350 GPM	760.5 m ³ /h
DISCHARGE SIZE	6"	152 mm
SUCTION SIZE	8"	203 mm
SOLIDS HANDLING	1.12"	2.8 cm
MAX SPEED	2200 RPM	2200 RPM
SHUT-OFF HEAD	365'	111.3 m
BEP HEAD	300'	91.4 m
BP FLOW	2600 GPM	590.2 m ³ /h
BEP PERCENT	86%	86%



A typical picture of the pump is shown. Please contact Aquarius Pump Company for further details. All information is approximate and for general guidance only.

PARTS	STANDARD MATERIAL (ALL IRON)	ALL IRON BRONZE FITTED
IMPELLER	CAST IRON ASTM A48 CL30	BRONZE SAE 40
VOLUTE	CAST IRON ASTM A48 CL30	CAST IRON ASTM A48 CL30
SHAFT	SAE 1144 "STRESSPROOF"	SAE 1144 "STRESSPROOF"
SHAFT SLEEVE	416 STAINLESS STEEL	BRONZE SAE 660
BEARING HOUSING	CAST IRON ASTM A48 CL30	CAST IRON ASTM A48 CL30
WEAR RINGS	CAST IRON ASTM A48 CL30	BRONZE SAE 660
SUCTION SPOOL	CAST IRON ASTM A48 CL30	CAST IRON ASTM A48 CL30
BACKPLATE	CAST IRON ASTM A48 CL30	CAST IRON ASTM A48 CL30
MECHANICAL SEAL (OPTIONAL)	T-1, BUNA, CARBON/CERAMIC/STAINLESS	T-1, BUNA, CARBON/CERAMIC/STAINLESS
PACKING	GRAPHITED ACRYLIC	GRAPHITED ACRYLIC

The 6H pump is designed with Aquarius's renowned quality and durability. It features a 6" discharge, 8" suction, enclosed impeller, and flanged tangential double volute. Available in all-iron or bronze-fitted materials. Graphited acrylic packing is standard, with Aquarius's patented Cycloseal available (with type 1 single mechanical seal). Grease lubrication standard - oil lubrication optional.

- External hydraulic balance line
- Back pullout design
- Replaceable hub & suction wear rings
- Replaceable shaft sleeve
- High efficiency hydraulics
- Low operating costs
- SAE #1, 2, 3, 4 & 5
- Modular bearing frame
- Oversized shaft and bearings
- Other mechanical seal (Cycloseal®) and material options available
- Two year warranty



AGRICULTURE



FOOD



INDUSTRIAL



MINING



MUNICIPAL



OIL & GAS



REFRIGERATION



RENTAL



AQUARIUS PUMP COMPANY

6H-F

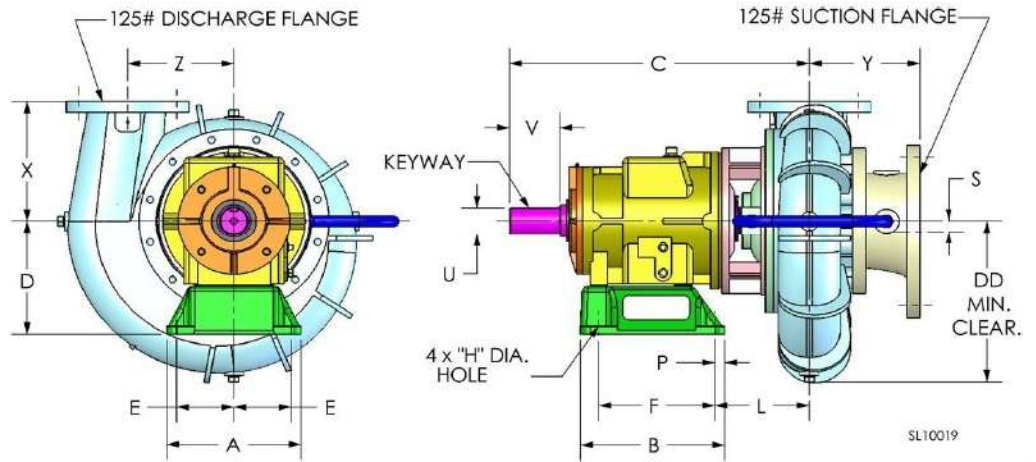

PUMP DIMENSIONS

MODEL	FRAME	CONNECTION		DISCH. INCR.	A	B	C	D	DD	E	F	H	L	P	S	U	V	X	Y	Z	KEYWAY
		DISCH.	SUCT.																		
3HA	F18	3	6	90°	12	12.88	29.11	10.5	11.12	5.12	10.38	0.81	10.74	0.88	0.44	2.5	4.5	10	8.53	8.5	.62X.31
3HC	F18	3	6	90°	12	12.88	25.88	10.5	11.12	5.12	10.38	0.81	7.5	0.88	0.44	2.5	4.5	10	8.53	8.5	.62X.31
4HC	F18	4	8	90°	12	12.88	26.97	10.5	12.62	5.12	10.38	0.81	8.6	0.88	0.88	2.5	4.5	11	10.88	9.75	.62X.31
4HH	F18	4	6	90°	12	12.88	29.14	10.5	15	5.12	10.38	0.81	10.77	0.88	0.44	2.5	4.5	9.5	8.97	11.25	.62X.31
5H	F18	5	8	90°	12	12.88	29.17	10.5	14.75	5.12	10.38	0.81	10.8	0.88	0.88	2.5	4.5	13	9.66	11.62	.62X.31
5HH	F18	5	8	90°	12	12.88	29.84	10.5	16.25	5.12	10.38	0.81	11.47	0.88	0.44	2.5	4.5	11	10.56	10.25	.62X.31
6H	F18	6	8	90°	12	12.88	29.14	10.5	14.75	5.12	10.38	0.81	10.77	0.88	0.44	2.5	4.5	14	10.18	11.62	.62X.31
6HH	F18	6	8	90°	12	12.88	30.13	10.5	17.12	5.12	10.38	0.81	11.91	0.88	0.44	2.5	4.5	12	10.43	12	.62X.31
8H	F18	8	10	90°	12	12.88	30.41	10.5	16.75	5.12	10.38	0.81	12.03	0.88	0.75	2.5	4.5	13	10.41	11.5	.62X.31

Feet x .305 = Meters
 Inches x 25.4 = Millimeters
 GPM x .227 = Cubic Meters/Hour
 GPM x 3.785 = Liters/Minute
 HP x .746 = KW

Speed	Impeller Dia.	Style	Solids Dia.	N _S	Suction	Discharge	No. vanes
VARIOUS	VARIOUS	ENCLOSED	1.12	1587	8"	6"	6

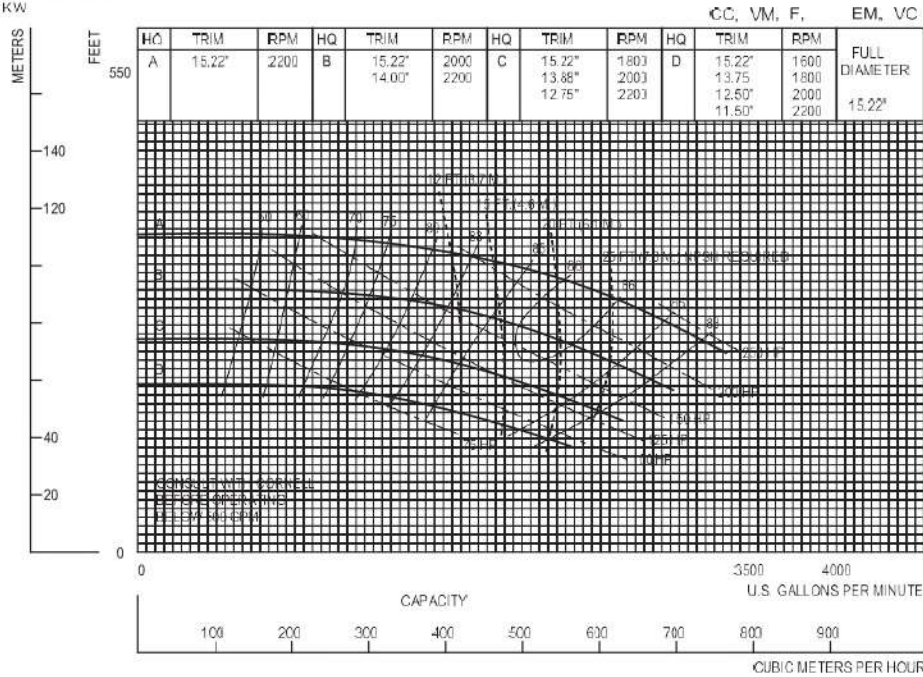

Performance shown is for cool water, clean, non-abrasive liquids. Other mounting configurations, seal arrangements or liquids may require horsepower and/or performance adjustments.



Aquarius Pump Company

6H - VARIOUS RPM

NEW PAGE 6HVA