



AQUARIUS PUMP COMPANY

6HH-CC

AVAILABLE MOUNTING CONFIGURATIONS

6H-CC CLOSE COUPLED
6H-VM VERTICAL CLOSE COUPLED

OPERATING LEVELS

| | | |
|-----------------|----------|-------------------------|
| MIN FLOW | 750 GPM | 170.3 m ³ /h |
| MAX FLOW | 3650 GPM | 829 m ³ /h |
| DISCHARGE SIZE | 6" | 152 mm |
| SUCTION SIZE | 8" | 203.2 mm |
| SOLIDS HANDLING | 1.22" | 3 cm |
| MAX SPEED | 1800 RPM | 1800 RPM |
| SHUT-OFF HEAD | 288' | 87.8 m |
| BEP HEAD | 245' | 74.7 m |
| BEP FLOW | 2850 GPM | 647.3 m ³ /h |
| BEP PERCENT | 86% | 86% |



A typical picture of the pump is shown. Please contact Aquarius Pump Company for further details. All information is approximate and for general guidance only.

| PARTS | CAST IRON BRONZE FITTED (STANDARD) | ALL IRON |
|----------------------------|-------------------------------------|-------------------------------------|
| IMPELLER | BRONZE SAE 40 OR SILICON BRONZE | CAST IRON ASTM A48 CL30 |
| VOLUTE | CAST IRON ASTM A48 CL30 | CAST IRON ASTM A48 CL30 |
| SHAFT | CARBON STEEL | CARBON STEEL |
| SHAFT SLEEVE | BRONZE SAE 660 | 416 STAINLESS STEEL |
| MOTOR | ODP W/ 1.15 SF | ODP W/ 1.15 SF |
| WEAR RINGS | BRONZE SAE 660 | CAST IRON ASTM A48 CL30 |
| SUCTION SPOOL | CAST IRON ASTM A48 CL30 | CAST IRON ASTM A48 CL30 |
| BACKPLATE | CAST IRON ASTM A48 CL30 | CAST IRON ASTM A48 CL30 |
| MECHANICAL SEAL (OPTIONAL) | T-1, BUNA, CARBON/CERAMIC/STAINLESS | T-1, BUNA, CARBON/CERAMIC/STAINLESS |
| PACKING | GRAPHITED ACRYLIC | GRAPHITED ACRYLIC |

The 6HH pump is designed with Aquarius's renowned quality and durability. It features a 6" discharge, 8" suction, enclosed impeller, and flanged tangential double volute. Available in all-iron or bronze-fitted materials. Graphited acrylic packing is standard, with Cornell's patented Cycloseal[®] available (with type 1 single mechanical seal). Optional motors include TEFC (other options available).

- Standard cast iron bronze fitted construction
- External hydraulic balance line
- Double volute construction
- Back pullout design
- Replaceable hub & suction wear rings
- Replaceable shaft sleeve
- "Shower curtain shield" bearing protection
- High efficiency hydraulics
- Low operating costs
- Two year warranty
- Other mechanical seal (Cycloseal[®]) and material options available



AGRICULTURE



FOOD



INDUSTRIAL



MINING



MUNICIPAL



OIL & GAS



REFRIGERATION



RENTAL



AQUARIUS PUMP COMPANY

6HH-CC

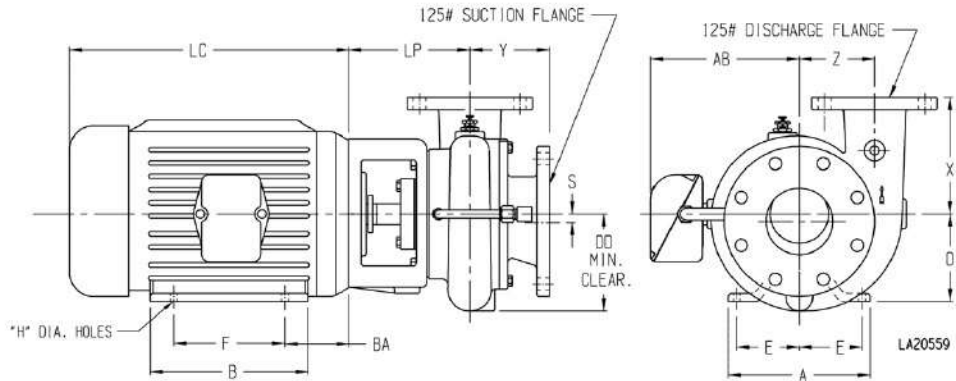

PUMP DIMENSIONS

| MODEL | CONNECTION | | DISCH. INCR. | AK DIM. | DD | S | X | Y | Z | LP |
|-------|------------|-------|--------------|---------|-------|------|-----|-------|-------|-------|
| | DISCH. | SUCT. | | | | | | | | |
| 2.5H | 2.5 | 4 | 90° | 8.5 | 9.62 | 0.44 | 11 | 8.28 | 7.75 | 7.66 |
| | | | | 12.5 | 9.62 | 0.44 | 11 | 8.28 | 7.75 | 7.66 |
| 3HA | 3 | 6 | 90° | 12.5 | 11.12 | 0.44 | 10 | 8.53 | 8.5 | 10.09 |
| 3HC | 3 | 6 | 90° | 12.5 | 11.12 | 0.44 | 10 | 8.53 | 8.5 | 10.09 |
| 4HC | 4 | 8 | 90° | 12.5 | 12.62 | 0.88 | 11 | 10.88 | 9.75 | 11.19 |
| 4HH | 4 | 6 | 90° | 12.5 | 15 | 0.44 | 9.5 | 8.97 | 11.25 | 10.12 |
| | | | | 16.5 | 16.25 | 0.44 | 11 | 10.56 | 10.25 | 10.81 |
| 5H | 5 | 8 | 90° | 12.5 | 14.75 | 0.88 | 13 | 9.66 | 11.62 | 10.15 |
| | | | | 16.5 | 16.25 | 0.44 | 11 | 10.56 | 10.25 | 10.81 |
| 5HH | 5 | 8 | 90° | 12.5 | 16.25 | 0.44 | 11 | 10.56 | 10.25 | 10.81 |
| | | | | 16.5 | 16.25 | 0.44 | 11 | 10.56 | 10.25 | 10.81 |
| 6H | 6 | 8 | 90° | 12.5 | 14.75 | 0.44 | 14 | 10.18 | 11.62 | 10.12 |
| | | | | 16.5 | 14.75 | 0.44 | 14 | 10.18 | 11.62 | 10.12 |
| 6HH | 6 | 8 | 90° | 12.5 | 17.12 | 0.44 | 12 | 10.43 | 12 | 11.13 |
| | | | | 16.5 | 17.12 | 0.44 | 12 | 10.43 | 12 | 11.13 |
| 8H | 8 | 10 | 90° | 12.5 | 16.75 | 0.75 | 13 | 10.41 | 11.5 | 11.38 |
| | | | | 16.5 | 16.75 | 0.75 | 13 | 10.41 | 11.5 | 11.38 |

MOTOR DIMENSION

| MOTOR FRAME | AK DIM. | A | B | D | E | F | H | AB | BA | LC |
|-------------|---------|-------|-------|------|------|-------|------|-------|------|-------|
| 213-5 | 8.5 | 9.5 | 8 | 5.25 | 4.25 | 7 | 0.41 | 7.94 | 4.5 | 13.69 |
| 254-6 | 8.5 | 11.25 | 11.25 | 6.25 | 5 | 10 | 0.53 | 9.5 | 5 | 17.94 |
| 284-6 | 12.5 | 12.25 | 12.25 | 7 | 5.5 | 11 | 0.53 | 11.37 | 5 | 21.31 |
| 324-6 | 12.5 | 14.25 | 13.75 | 8 | 6.25 | 12 | 0.66 | 12.22 | 5.5 | 22.19 |
| 364-5 | 12.5 | 15.75 | 14 | 9 | 7 | 12.25 | 0.66 | 13.2 | 6.12 | 24.31 |
| 404-5 | 12.5 | 18.5 | 16.62 | 10 | 8 | 13.75 | 0.81 | 16.39 | 6.88 | 29.97 |
| 444-5 | 16.5 | 21.5 | 19.5 | 11 | 9 | 16.5 | 0.81 | 19.06 | 7.5 | 31 |

| Speed | Impeller Dia. | Style | Solids Dia. | N _s | Suction | Discharge | No. vanes |
|-------|---------------|----------|-------------|----------------|---------|-----------|-----------|
| 1785 | VARIOUS | ENCLOSED | 1.22" | 1568 | 8" | 6" | 6 |

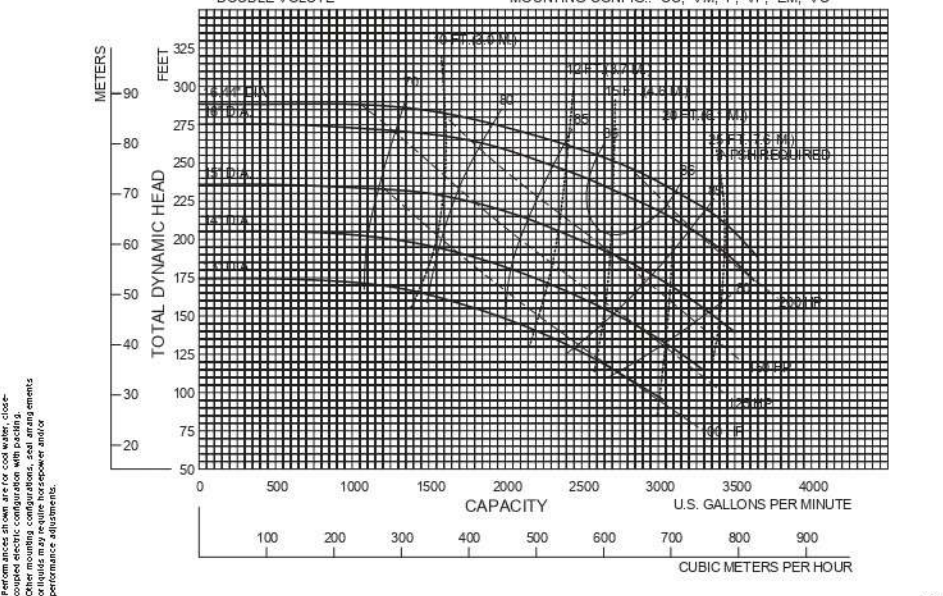

Aquarius Pump Company 6HH - 1800 RPM