



# AQUARIUS PUMP COMPANY

## 6YB-F

### AVAILABLE MOUNTING CONFIGURATIONS

6YB-RP-F REDI-PRIME FRAME MOUNT  
 6YB-RP-EM REDI-PRIME ENGINE MOUNT  
 6YB-F FRAME MOUNT  
 6YB-EM ENGINE MOUNT

### OPERATING LEVELS

<b>MIN FLOW</b>	800 GPM	181.7 m3/h
<b>MAX FLOW</b>	4,125 GPM	936.89 m3/h
<b>DISCHARGE SIZE</b>	6"	152.4 mm
<b>SUCTION SIZE</b>	10"	254 mm
<b>MAX SPEED</b>	2,400 RPM	2,400 RPM
<b>SOLIDS HANDLING</b>	.75"	19.05 mm
<b>MAX PRESSURE</b>	175 PSID	1,206.58 kPa
<b>SHUT-OFF HEAD</b>	240' @ 103.9 PSID	73.15 m @ 716.37 kPa
<b>BEP HEAD</b>	155' @ 67.1 PSID	47.24 m @ 462.64 kPa
<b>BEP FLOW</b>	3,350 GPM	760.87 m3/h
<b>BEP EFFICIENCY</b>	85%	85%



A typical picture of the pump is shown. Please contact Aquarius Pump Company for further details. All information is approximate and for general guidance only.

PARTS	CAST IRON BRONZE FITTED	ALL IRON
<b>WEAR RING</b>	BRONZE SAE 660	CAST IRON ASTM A48 CL30
<b>IMPELLER</b>	BRONZE SAE 40	CAST IRON ASTM A48 CL30
<b>VOLUTE</b>	CAST IRON ASTM A48 CL30	CAST IRON ASTM A48 CL30
<b>SHAFT</b>	SAE 1144 "STRESSPROOF"	SAE 1144 "STRESSPROOF"
<b>SHAFT SLEEVE</b>	BRONZE SAE 660	303 STAINLESS STEEL
<b>PACKING</b>	GRAPHITED ACRYLIC	GRAPHITED ACRYLIC
<b>MECHANICAL SEAL</b>	T-1, BUNA-CARBON/CERAMIC	T-1, BUNA-CARBON/CERAMIC
<b>BACKPLATE</b>	CAST IRON ASTM A48 CL30	CAST IRON ASTM A48 CL30
<b>BEARING FRAME</b>	CAST IRON ASTM A48 CL30	CAST IRON ASTM A48 CL30

The 6YB pump is designed with Aquarius's renowned quality and durability. It features a 6" discharge and a 10" suction, enclosed multi-vane impeller, and flanged tangential double volute. Available in standard Cast-Iron Bronze Fitted or All Iron. Optional Redi-Prime or Venturi Prime priming system is available. Pump end mounts to F5, EM5, F16, and EM16 bearing frames. Bearings are heavy-duty, grease lubricated, single ball bearings with a minimum of 20,000 hours bearing life.

- Industry-leading two-year warranty
- Industry-leading efficiencies
- External hydraulic balance line
- Replaceable suction wear ring and shaft sleeve
- Heavy-duty modular bearing frame
- Grease lubrication standard - oil optional
- Large shaft and bearings
- RunDry™ option (Indefinite run dry capability)
- Optional Cycloseal® with T-1 mechanical seal
- SAE #3, 4 & 5 engine mount available



AGRICULTURE



FOOD



INDUSTRIAL



MINING



MUNICIPAL



OIL & GAS



REFRIGERATION



RENTAL



**PRODUCT DATA SHEET**

# AQUARIUS PUMP COMPANY

## 6YB-F

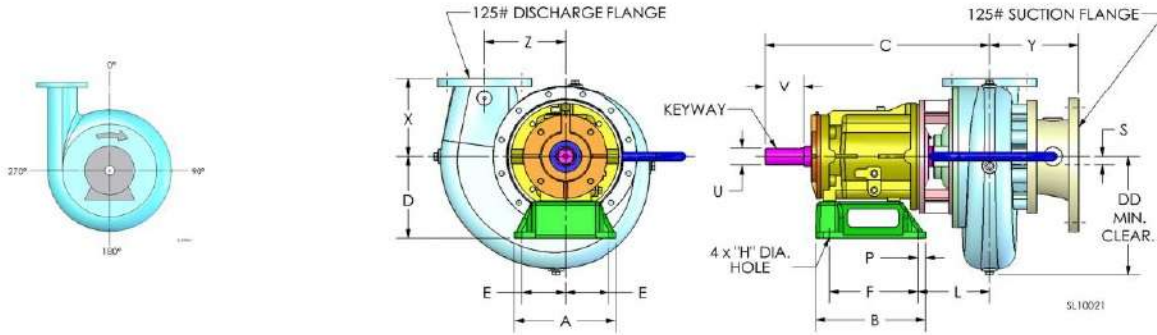

**NOTES:**

Discharge positions are viewed from the drive end.  
 Standard increments of discharge position are shown in the chart below (DISCH INCR). Consult factory for other discharge positions.

**NOTES:**

1. "V" Dimension is maximum useable shaft.
2. Frame mounting foot thickness is .75".
3. Flange connection dimension can vary ± .12 inch.
4. Do not use for construction unless certified.

PUMP DIMENSIONS																					
MODEL	FRAME	CONNECTION DISCH.	CONNECTION SUCT.	DISCH. INCR.	A	B	C	D	DD	E	F	H	L	P	S	U	V	X	Y	Z	KEYWAY
6YB	F16	6	10	90°	12	12.88	29.69	9.75	14.75	5.12	10.38	0.81	11.81	0.88	1	2	4.5	9.5	10.41	9.5	.50X.25

