



# AQUARIUS PUMP COMPANY

## 8H-CC

### AVAILABLE MOUNTING CONFIGURATIONS

8H-CC CLOSE COUPLED  
8H-VM VERTICAL CLOSE COUPLED

### OPERATING LEVELS

MIN FLOW	900 GPM	204.4 m <sup>3</sup> /h
MAX FLOW	4950 GPM	1124.3 m <sup>3</sup> /h
DISCHARGE SIZE	8"	203 mm
SUCTION SIZE	10"	254 mm
SOLIDS HANDLING	1.25"	3.2 cm
MAX SPEED	1800 RPM	1800 RPM
SHUT-OFF HEAD	250'	76 m
BEP HEAD	200'	61 m
BEP FLOW	3650 GPM	829 m <sup>3</sup> /h
BEP PERCENT	88%	88%



A typical picture of the pump is shown. Please contact Aquarius Pump Company for further details. All information is approximate and for general guidance only.

PARTS	ALL IRON	CAST IRON BRONZE FITTED
IMPELLER	CAST IRON ASTM A48 CL30	BRONZE SAE 40 OR SILICON BRONZE
VOLUTE	CAST IRON ASTM A48 CL30	CAST IRON ASTM A48 CL30
SHAFT	CARBON STEEL	CARBON STEEL
SHAFT SLEEVE	416 STAINLESS STEEL	BRONZE SAE 660
MOTOR	ODP W/ 1.15 SF	ODP W/ 1.15 SF
WEAR RINGS	CAST IRON ASTM A48 CL30	BRONZE SAE 660
SUCTION SPOOL	CAST IRON ASTM A48 CL30	CAST IRON ASTM A48 CL30
BACKPLATE	CAST IRON ASTM A48 CL30	CAST IRON ASTM A48 CL30
MECHANICAL SEAL (OPTIONAL)	T-1 OR T2, BUNA, CARBON/CERAMIC/STAINLESS	T-1 OR T2, BUNA, CARBON/CERAMIC/STAINLESS
PACKING	GRAPHITED ACRYLIC	GRAPHITED ACRYLIC

The 8H pump is designed with Aquarius's renowned quality and durability. It features a 8" discharge, 10" suction, enclosed impeller, and flanged tangential double volute. Available in all-iron or bronze-fitted materials. Graphited acrylic packing is standard, with Aquarius's patented Cycloseal available (with type 1 single mechanical seal). Optional motors include TEFC (other options available).

- Standard cast iron bronze fitted construction
- External hydraulic balance line
- Double volute construction
- Back pullout design
- Replaceable hub & suction wear rings
- Replaceable shaft sleeve
- "Shower curtain shield" bearing protection
- High efficiency hydraulics
- Low operating costs
- Two year warranty
- Other mechanical seal (cycloseal) and material options available



AGRICULTURE



FOOD



INDUSTRIAL



MINING



MUNICIPAL



OIL & GAS



REFRIGERATION



RENTAL



# AQUARIUS PUMP COMPANY

## 8H-CC

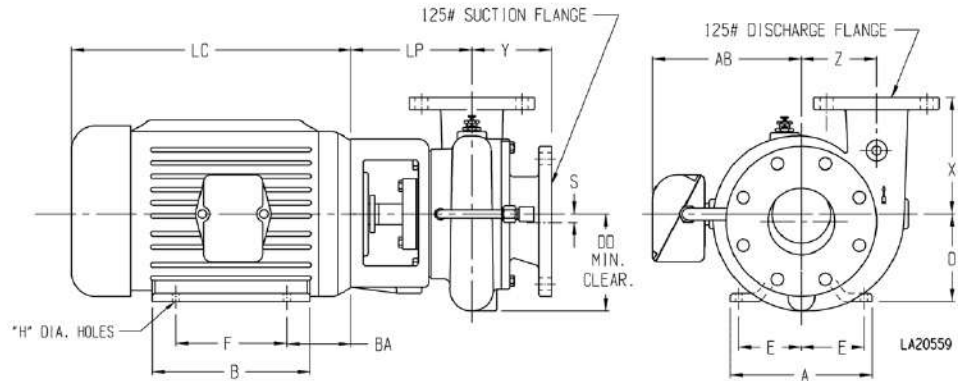

PUMP DIMENSIONS

MODEL	CONNECTION		DISCH. INCR.	AK DIM.	DD	S	X	Y	Z	LP
	DISCH.	SUCT.								
2.5H	2.5	4	90°	8.5	9.62	0.44	11	8.28	7.75	7.66
				12.5	9.62	0.44	11	8.28	7.75	7.66
3HA	3	6	90°	12.5	11.12	0.44	10	8.53	8.5	10.09
3HC	3	6	90°	12.5	11.12	0.44	10	8.53	8.5	10.09
4HC	4	8	90°	12.5	12.62	0.88	11	10.88	9.75	11.19
4HH	4	6	90°	12.5	15	0.44	9.5	8.97	11.25	10.12
				16.5	16.25	0.44	11	10.56	10.25	10.81
5H	5	8	90°	12.5	14.75	0.88	13	9.66	11.62	10.15
				16.5	16.25	0.44	11	10.56	10.25	10.81
5HH	5	8	90°	12.5	16.25	0.44	11	10.56	10.25	10.81
				16.5	16.25	0.44	11	10.56	10.25	10.81
6H	6	8	90°	12.5	14.75	0.44	14	10.18	11.62	10.12
				16.5	14.75	0.44	14	10.18	11.62	10.12
6HH	6	8	90°	12.5	17.12	0.44	12	10.43	12	11.13
				16.5	17.12	0.44	12	10.43	12	11.13
8H	8	10	90°	12.5	16.75	0.75	13	10.41	11.5	11.38
				16.5	16.75	0.75	13	10.41	11.5	11.38

MOTOR DIMENSION

MOTOR FRAME	AK DIM.	A	B	D	E	F	H	AB	BA	LC
213-5	8.5	9.5	8	5.25	4.25	7	0.41	7.94	4.5	13.69
254-6	8.5	11.25	11.25	6.25	5	10	0.53	9.5	5	17.94
284-6	12.5	12.25	12.25	7	5.5	11	0.53	11.37	5	21.31
324-6	12.5	14.25	13.75	8	6.25	12	0.66	12.22	5.5	22.19
364-5	12.5	15.75	14	9	7	12.25	0.66	13.2	6.12	24.31
404-5	12.5	18.5	16.62	10	8	13.75	0.81	16.39	6.88	29.97
444-5	16.5	21.5	19.5	11	9	16.5	0.81	19.06	7.5	31

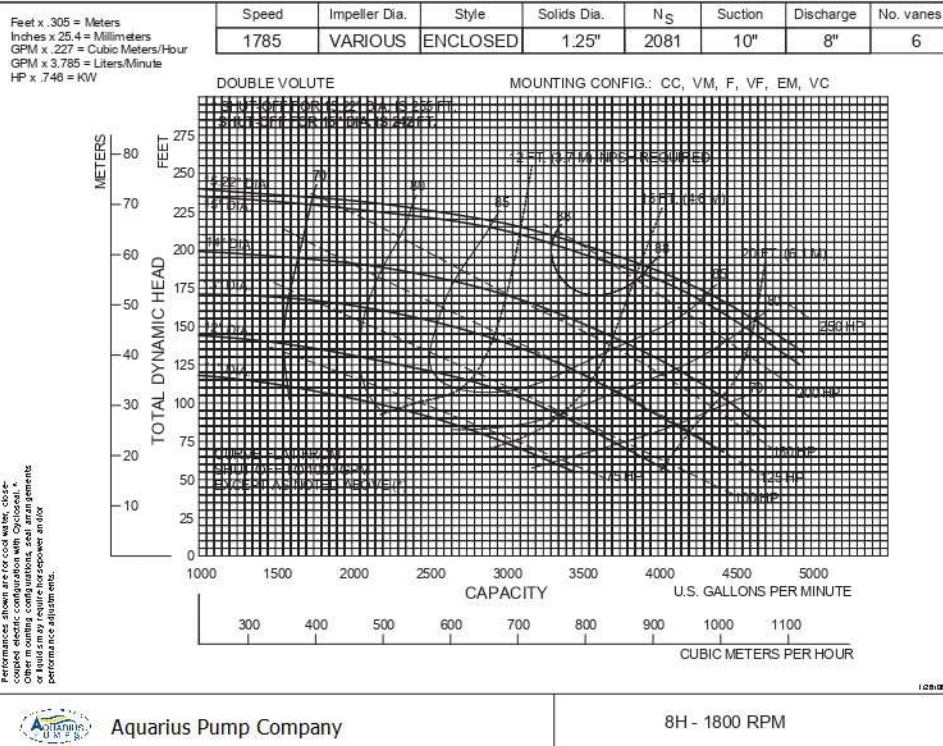

NEW PAGE

8H18